

Vibration Isolation Table

Features

The vibration isolation table is designed to provide maximum stability and keep vibration to a minimum.

The system does not require a constant air supply. The air supply to the isolation system is done with a hand pump manually. Leveling is accomplished by adjusting the three air valves on the front face.

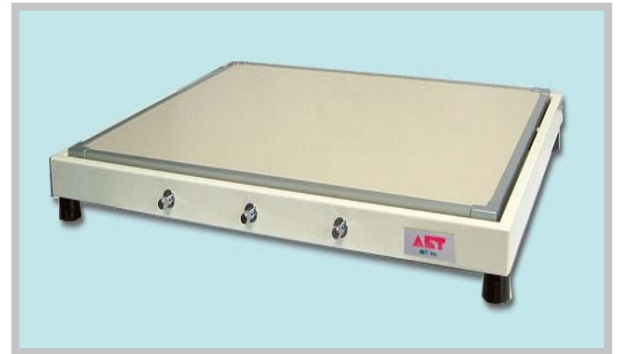

Specifications

Types	ABSDT0607-1D	ABSDT0607-3D
Natural frequency	Vertical: 1.5-3.0Hz	Horizontal: 1.0-2.0Hz Vertical: 1.5-3.0Hz
Vibration isolation method	Air suspension	
Damping method	Air damping using orifice	
Air supply method	Manual: hand air pump	
Leveling method	Manual: operation of 3 air valves	
Surface of top plate (select ① or ②)	① Polyvinyl chloride sheet ② Stainless steel plate	
Load weight	70Kg	
Machine leg material	Rubber	Rigid insulator
Accessories	Hand air pump (1 pcs.)	

Part Names/Dimensions

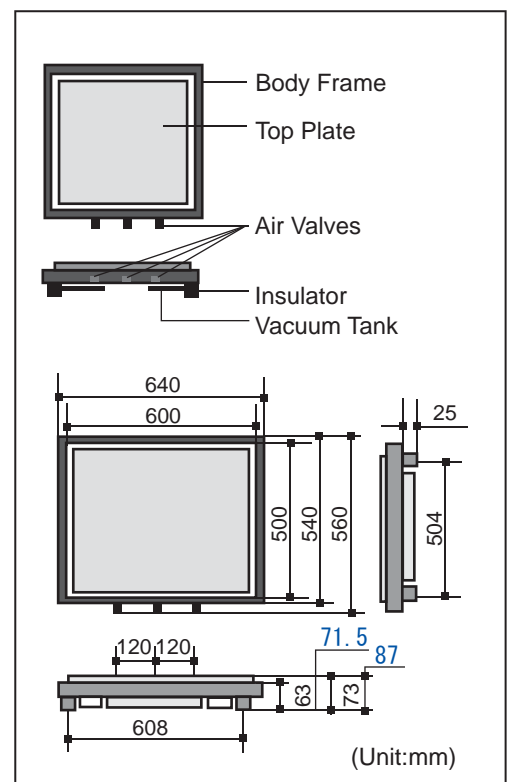

Transmissibility Load=34kg

— with horizontal vibration isolation
— without horizontal vibration isolation

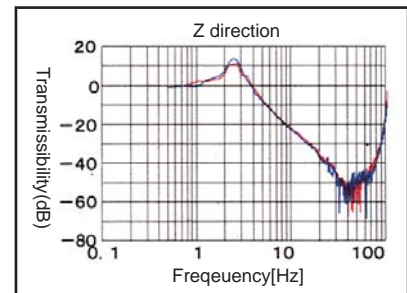
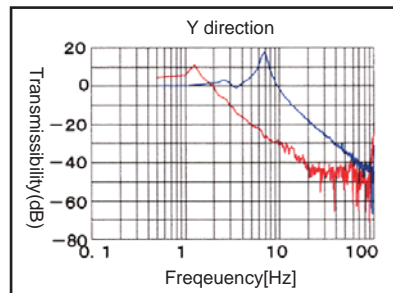
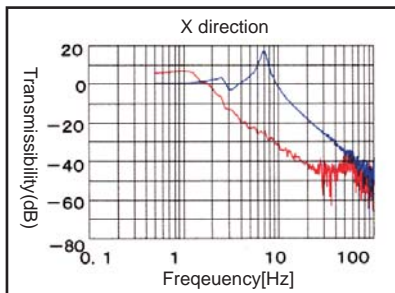

Vibration Isolation Desk

Features

The vibration isolation desk is designed to provide maximum stability and reduce vibration to a minimum.

●Manual type: The air supply to the isolation system is done with a hand pump manually. Leveling is accomplished by adjusting the three air valves.

●Auto type: The air supply to the isolation system is done with continuous compressed air. Leveling is accomplished by the automatic leveling sensors automatically.

Specifications

Types	ABSDSK0607-1D	ABSDSK0607-3D
Natural frequency	Vertical: 1.0-2.0Hz	Horizontal: 1.0-2.0Hz Vertical: 1.0-2.0Hz
Vibration isolation method	Air suspension	
Damping method	Air damping using orifice or universal system*	
Air supply (select ①or②)	①Manual type: hand air pump ②Auto type: air compressor, etc. (0.3-0.5MPa pressure required)	
Leveling (select ①or②)	①Manual type: operation of 3 air valves ②Auto type: automatic leveling sensors keep the surface level automatically	
Surface of top plate	Stainless steel plate SUS-410 5t	
Materials of top plate	High density steel honeycomb bench	
Size of top plate	800mm(W)×600mm(D)	
Load weight	130Kg	
Machine dimension	860mm(W)×710mm(D)×650mm(H)	
Machine weight	120kg	
Accessories	Hand air pump (1 pcs.)	

* Universal system utilizes a damping method applying a double pendulum system.

Transmissibility Load=80kg

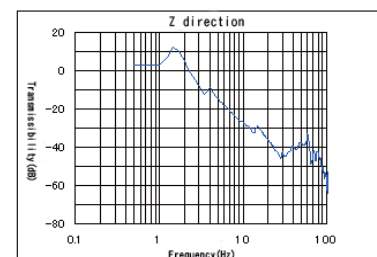
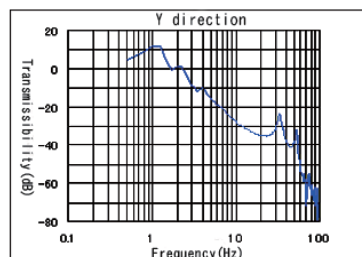
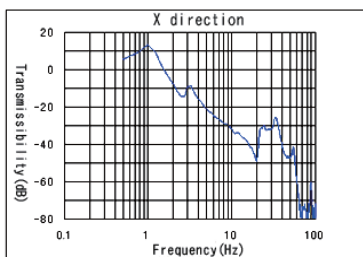

Part Names/Dimensions

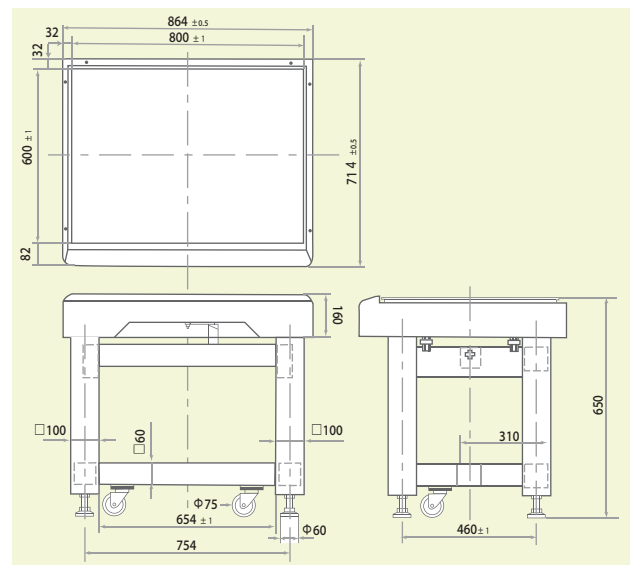

Equipments



Automatic Leveling Sensors (Auto type)



Earth Terminal